

REF	DESCRIPTION	MATERIAL	CODE
10	Containment shell	SS 316L	
20	Ext. Magnet	CoSm/ Carbon Steel	
30	Int. Magnet	SS 316L/CoSm	
40	Impeller	SS 316L	
50	Set O-Rings (a+b+c) a + b = O-Ring 4300 (234) c = O-Ring 4362 (239)	Viton	
61	Thrust Bearings	Pcarbon	
62	Rear Ring	SS316L	
70	Shaft	SIC	
75	Sleeve Bearings Bearings (d+e) Bearing (f)	SIC SS316	
78	Bracket (168-114-19)	Cast Iron	
79	Rub Ring	Bronze	
84	End Cover	SS 316L	
85	Pump Casing	SS 316L	
88	Rear Wet End (10+30+40+50+61+62+70+75)	/	

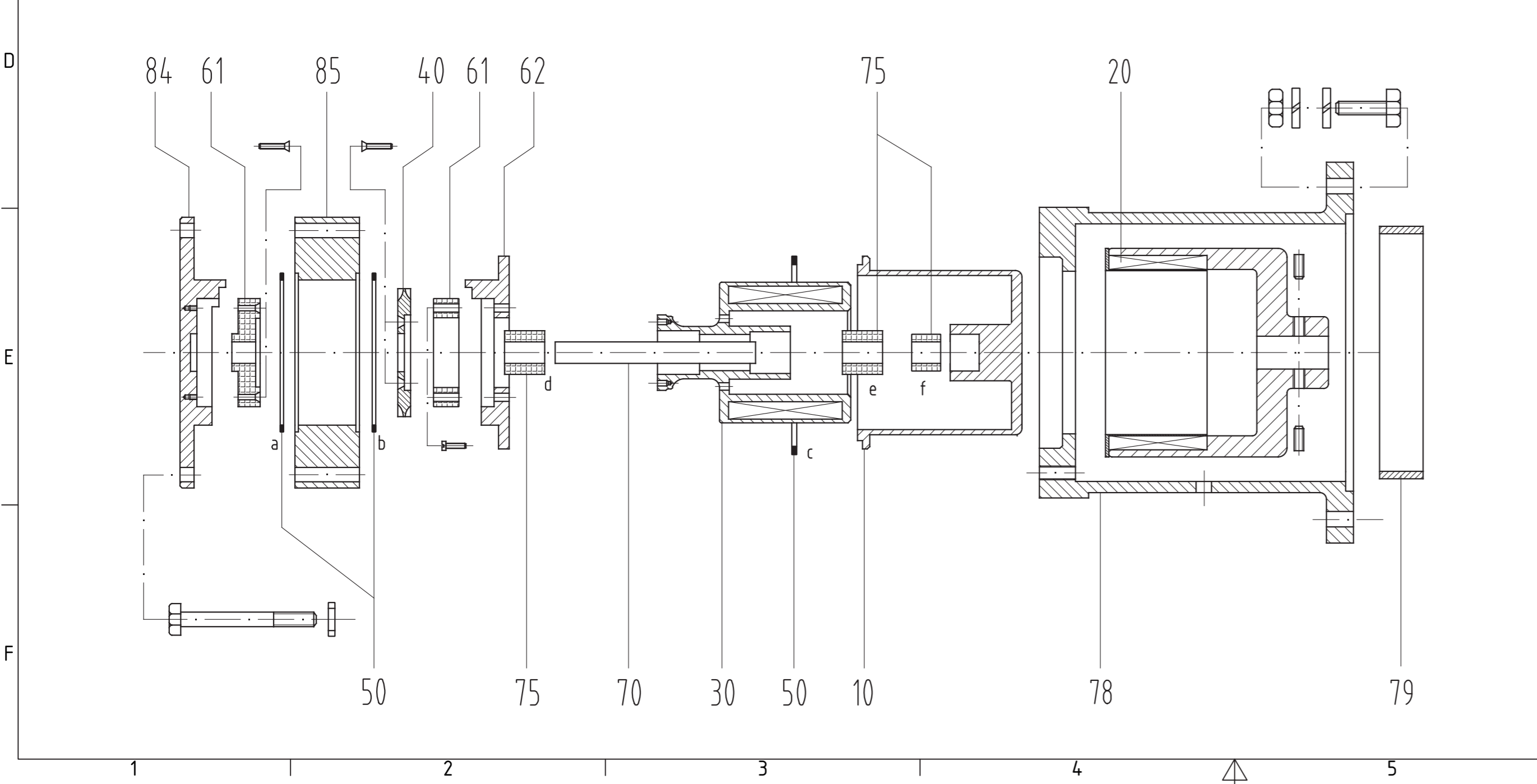

Alle Angaben unverbindlich, technische Änderungen vorbehalten! Technical data not binding and subject to change!
Copyright MARCH PUMPEN GmbH & Co.KG 2021

	MARCH PUMPEN GmbH & Co.KG Rätthausstraße 2 D-35394 Gießen info@march-pumpen.com www.march-pumpen.com			Allgemeintoleranzen nach DIN ISO 2768-m Alle Kanten gratfrei	
	Gezeichnet Kontrolliert Norm	Datum 31.05.2021		Name Lach	Series MTA MTA37 NPT NEMA
DPCA-MTA-0037				1 A2	
Status	Änderungen	Datum	Name		